

St Paul's Church of England
Combined School
Year 2 SATs meeting

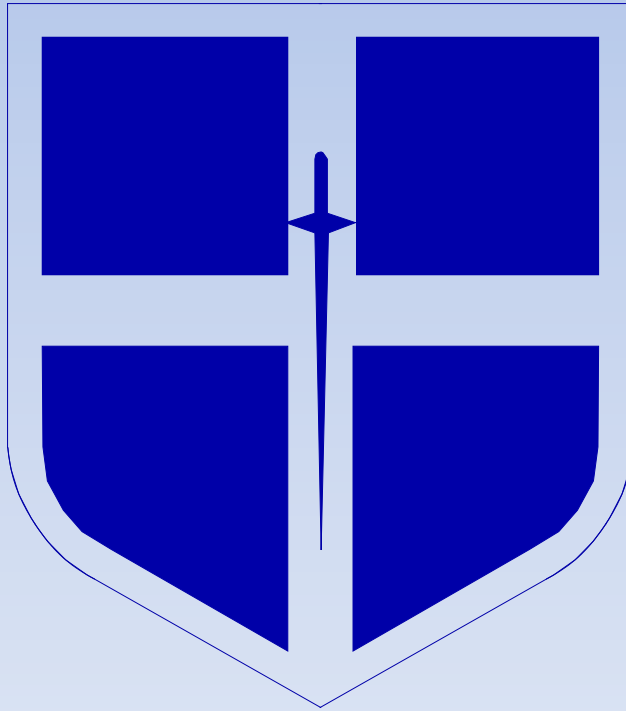

Growing in Strength, Wisdom and Faith

When, what and how?

- SATs will take place around May/June time.
- They will be carried out in small groups and some whole class with an adult close by.
- They are **NOT** timed.
- 6 assessment papers in total...

Maths...

- Arithmetic Paper
 - 20 questions
 - Covers addition, subtraction, multiplication, division and fractions
- Reasoning Paper
 - Between 30/35 worded/problem solving questions
 - Selection of questions covering all elements of the Year 2 mathematics curriculum
 - Questions can be read to them (except key mathematical vocabulary)
 - The paper starts off with 5 questions that are verbally read by the teacher

Arithmetic Paper

13 $8 \times 10 =$

23 $65 +$ $= 93$

9 $8 + 5 + 4 =$

10 $36 + 24 =$

25 $\frac{3}{4}$ of 40 =

20 $86 - 21 =$

16 $12 \div 2 =$

Reasoning Paper

19 Amy buys an ice-cream for 90p.



(a) Tick (✓) **three** coins to show how Amy can make **90p**.







(b) Tick (✓) **four** coins to show another way to make **90p**.

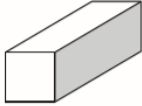
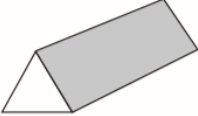

14 One shape is in the **wrong** place on the sorting grid.

Draw a cross (X) on it.

Shapes with a square face	Shapes without a square face
	
	
	

11 Use a ruler to measure the length of the toy car.

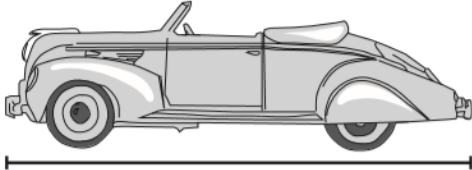

cm

22 Amy plants **4** rows of carrots.

There are **3** carrots in each row.

A rabbit eats **2** of the carrots.

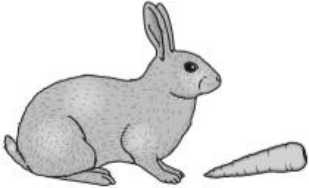

How many carrots are left?

carrots

Show your working

17 Sam is collecting cards.

He wants to collect **100** cards altogether.

Last week he collected **50** cards.

This week he collects **30** cards.



How many **more** cards does he need?

cards

Reading...

- Reading Paper 1

- 20 questions
- 2/3 texts broken into short passages (fiction, non-fiction, poetry)
- Retrieval, prediction, inference, sequencing

- Reading Paper 2

- A reading booklet and answer booklet
- Around 20 questions
- Retrieval, prediction, inference, sequencing

Reading Paper 1

9 Find and copy one word which tells you that Monster was not feeling well in the boat.

12

How do you know that Frog was excited?

20 Number the sentences below from 1 to 4 to show the order they happen in the story.

The first one has been done for you.

They found a big basket.

They fell asleep on an island.

They went in a boat.

The boat drifted away from them.

10

Frog spotted something on the water.

What does the word *spotted* mean in this sentence?

Tick **one**.

smelt

heard

felt

saw

15

How can you tell that it was late when Monster and Frog woke up?

Reading Paper 2

(page 6)

6 The blackbird said: "You and I are at war."

How do you know that the king was **not** worried by this?

(page 7)

8 Find and copy **two** words that describe how scared the king was.

1. _____

2. _____

10 Tick **two** good points about plastics.

Plastics can be...

nice to smell.

any shape.

grown.

eaten.

many colours.

Tick **two**.

5 For years he's drained me and dirtied me.

What does the word *drained* mean?

Tick **one**.

filled up with water

stirred up the water

emptied out the water

worn out the water

18 Put ticks in the table to show which sentences are **true** and which are **false**.

One has been done for you.

The information says that...	True	False
recycling is a good way to get rid of unwanted plastics.	✓	
we should use more things made of plastic.		
today we use plastics a lot.		
plastic is hard to get rid of.		
plastics rot.		

SPAG (Spelling, Grammar and Punctuation)...

- Spelling Paper

- 20 questions
- Dictation style sentences with the spelling word missing
- Covering a range of spelling rules taught across Year 2 (inc. suffixes and prefixes)

- Grammar and Punctuation Paper

- 20 questions
- Word classes, tenses, sentence types, punctuation, suffixes/prefixes, plurals, contractions, conjunctions

Spelling Paper

1. Hannah ran _____ than Lee.
2. Yesterday it was very _____.
3. I had a big smile on my _____.
4. There was a large _____ of children at the party.

5. You pick things up with your _____.
6. The _____ in the box are different colours.
7. Our new _____ is black with white paws.

Qu.	Spelling	Mark	Content domain reference
1	faster	1	S7 – Adding <i>-er</i> and <i>-est</i> to adjectives where no change is needed to the root word
2	sunny	1	S26 – Adding <i>-ing</i> , <i>-ed</i> , <i>-er</i> , <i>-est</i> and <i>-y</i> to words of one syllable ending in a single consonant letter after a single vowel letter
3	face	1	S15 – The /s/ sound spelt <i>c</i> before <i>e</i> , <i>i</i> and <i>y</i>
4	group	1	S8 – Vowel digraphs and trigraphs
5	fingers	1	S5 – Adding <i>s</i> and <i>es</i> to words
6	paints	1	S8 – Vowel digraphs and trigraphs
7	kitten	1	S11 – Using <i>k</i> for the /k/ sound
8	thanked	1	S6 – Adding the endings <i>-ing</i> , <i>-ed</i> and <i>-er</i> to verbs where no change is needed to the root word
9	Saturday*	1	S13 – The days of the week
10	sweets	1	S8 – Vowel digraphs and trigraphs
11	baking	1	S25 – Adding the endings <i>-ing</i> , <i>-ed</i> , <i>-er</i> , <i>-est</i> and <i>-y</i> to words ending in <i>-e</i> with a consonant before it

8. I _____ my friend for her help.
9. We are going on holiday on _____.
10. I am not allowed to eat too many _____.

Putting ourselves in their shoes...

- How many of these do you think you know?:
 - A verb...
 - A contraction...
 - A coordinating conjunction...
 - A noun...
 - A suffix...
 - A subordinating conjunction...
 - An adjective...
 - A prefix...
 - A subordinator...
 - An adverb...
 - A homophone...
 - A pronoun...
 - A root word...

Grammar and Punctuation Paper

Write **s** or **es** to make each word a plural.

fox_____

card_____

match_____

Write one word on the line below to complete the sentence in the **past tense**.

I _____ to Scotland during the school holidays.

Write the missing punctuation mark to complete the sentence below.

Can you play my favourite tune

Tick one box to show where a **comma** should go in the sentence below.

Tick **one**.

Aisha found some red blue and purple beads in the box.

Tick the correct word to complete the sentence below.

I hope _____ we will play musical chairs at the party.

Tick **one**.

when

if

that

because

Draw lines to match the groups of words that have the same meaning.

One has been done for you.

I will	it's
you have	I'll
it is	didn't
did not	you've

(A line is drawn from 'did not' to 'didn't')

Circle the **verbs** in the sentence below.

Yesterday was the school sports day and Jo wore her new running shoes.

Do not panic!

- We do not want anybody worrying about these assessments. They are more our worry than yours!
- It is really important that the children do NOT know about these assessments. They will perform so much better without any worry/anxiety or stress.
- Their best is good enough. Our teacher assessment will count for more than the assessments.

How can you help at home?

- Apps/Websites:

- Classroom Secrets Kids
- T Rockstars/Numbots
- Hit the Button
- BBC Bitesize – Small Town Superheroes

- In the car:

- Counting in 2s, 5s, 10s, 3s, 10 more/less
- Quick spellings

- At home...

- Daily reading - ask additional questions about the text
- Maths – ask the children to explain how they worked something out.
- Spelling -Practice the weekly spellings and go back through previous weeks ones too – can they remember the rule?
- Grammar – charades or hangman with a noun/verb/adjective/adverb focus

**Remember to NOT mention it to your child – they do not need to know!
Don't panic or stress, they will all be absolutely AMAZING!**



Support at home

- We have put some work up on Teams to support your child at home as part of the preparation.
- Please keep this very low key with them and have a look at a small section as and when you can.
- Please read daily and update GoRead– this is just so important to all aspects of the children’s learning.
- Talk through your child’s learning. So much learning can happen through the talking and explaining, especially in maths.

Any questions?
